



**Parts Manual**

**Model: 690-G**

**Covers Serial Number Range:**

**519-K-69TKS9Y2-02519 through \_\_\_\_\_**

**Sold & Serviced By:**



# Contents

Quick Ordering .....	1
Front Paver Assembly.....	3
Engine Assembly.....	5
Hydraulic Tank .....	7
Hydraulic Components .....	9
Dash.....	11
Main Screed .....	13
Right Extension .....	15
Left Extension.....	17
Right Track Assembly .....	19
Left Track Assembly.....	21
Left Extension.....	23
Electrical Schematic.....	25
Hydraulic Schematic .....	27

**Quick Ordering**

BOM ID	Part Number	Description	Quantity
1	111-200080	Auger Hanger Support Assembly	2
2	018-0103	Auger Hanger Support Bearing	2
3	015-0045	Auger Coupling Chain	2
4	015-0154	Auger Coupling Half	2
5	092-0014	Auger (LH)	1
6	092-0013	Auger (RH)	1
7	050-0341	Cable, Steering	2
8	050-0347	Cable, Throttle	1
9	050-0522	Cap (Fuel Tank)	1
10	060-0069	Cap (Hydraulic Tank)	1
11	050-0188	Cap (Wash Down Tank)	1
12	024-0026	Decal Kit	1
13	010-0407	Alternator / Fan Belt	1
14	021-0132	Filter, Engine Oil	1
15	021-0068	Filter, Fuel (in-line)	1
16	021-0078	Filter, Water Separator	1
17	021-0169	Filter, Hydraulic Oil (High Pressure)	1
18	015-0222	Plastic, Front Hopper	1
19	091-0006	Push Roller Assembly	2
20	112-109290	Screed Burner Assembly	2
21	090-0231	Screed Lighting Torch Assembly	1
22	111-200008	Main Screed Plate	1
23	050-0361	Spray Nozzle	2
24	015-0275	Sprocket, Drive	2
25	050-0624	Sprocket, Idler Assembly	2
26	050-0257	Track Roller	6
27	020-0562	Igniter, Propane	4
28	020-0357A	Asphalt Material Switch	2

**This Page Left Blank  
Intentionally**

### Front Paver Assembly

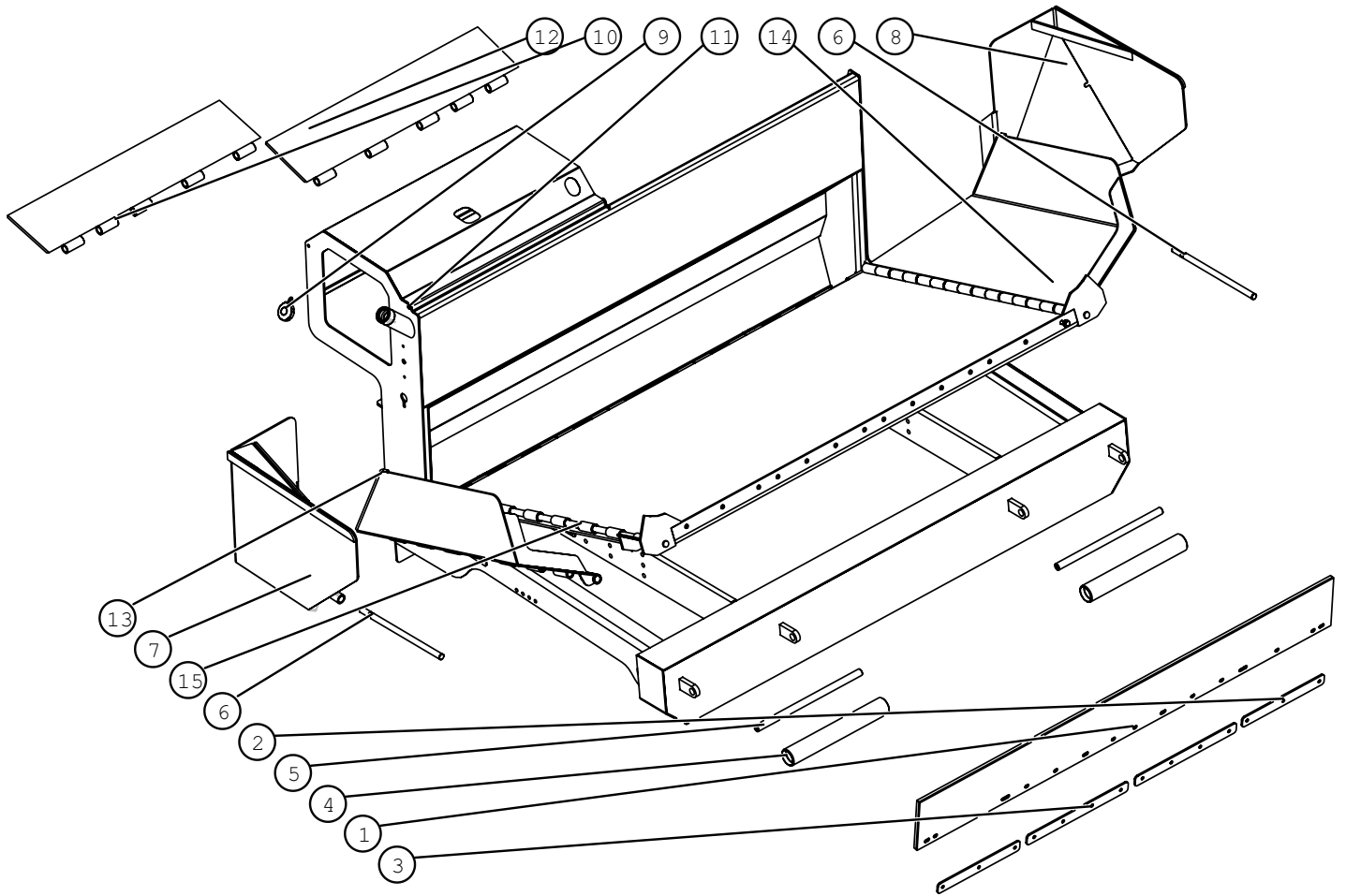

**Front Paver Assembly**

BOM ID	Part Number	Description	Quantity
1	015-0222	Front Plastic	1
2	093-100752	Plastic Retainer 3 Hole	2
3	093-100750	Plastic Retainer 4 Hole	2
4	091-0006	Push Roller	2
5	093-0038	Shaft Push Roller	2
6	093-206018	Rear Hopper Shaft	2
7	092-410070	Rear Hopper Right	1
8	092-410071	Rear Hopper Left	1
9	050-0522	Fuel Cap	1
10	092-410050	Gate Material RH	1
11	092-410220	Engine Compartment Hood	1
12	092-410051	Gate Material LH	1
13	092-410032	Front Right Hopper	1
14	092-410033	Front Left Hopper	1
15	093-100675	Hopper Hinge Pipe	22

### Engine Assembly

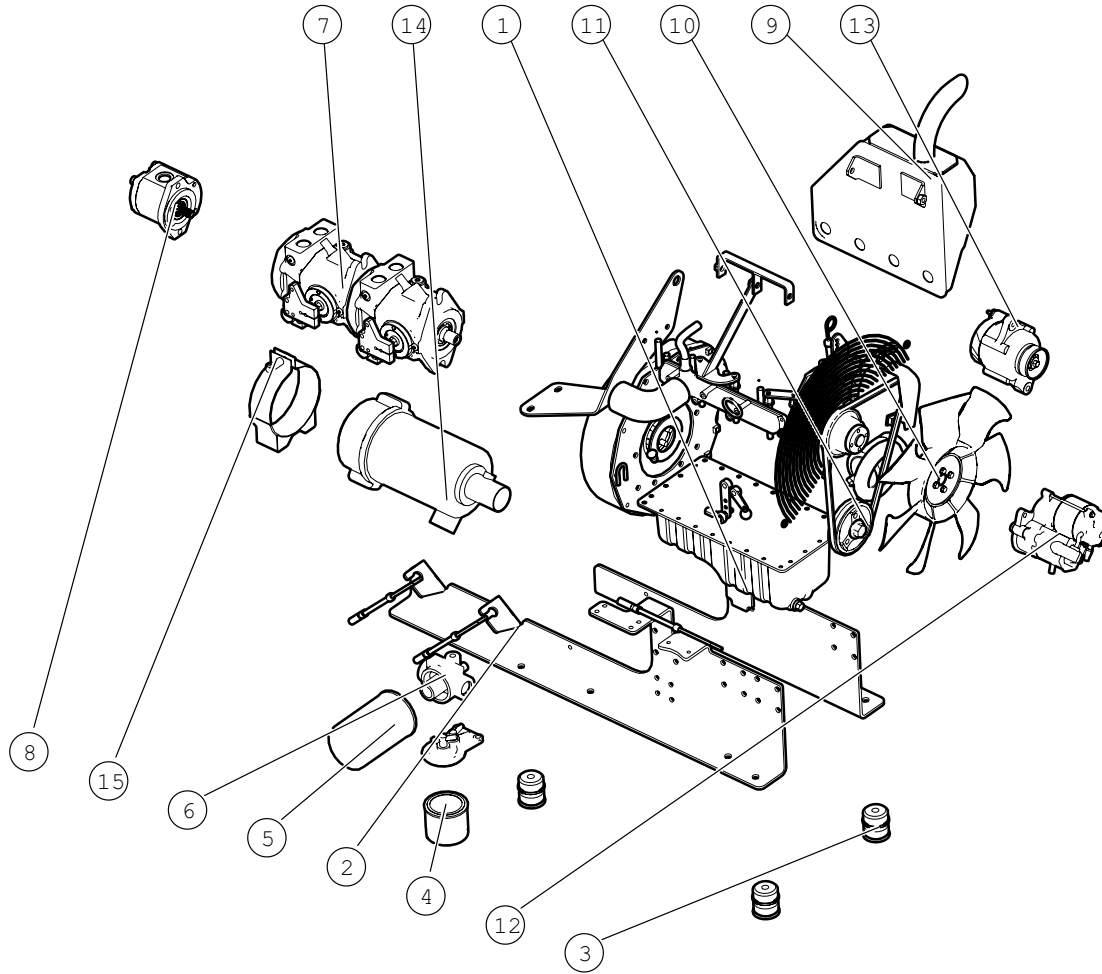



**Engine Assembly**

BOM ID	Part Number	Description	Quantity
1	093-200256	Engine Leg Left	1
2	093-200255	Engine Leg Right	1
3	050-0260	Rubber Isolator	4
4	021-0078	Filter Fuel	1
5	021-0169	Filter Hydraulic	1
6	021-0192	Filter Head Hydraulic	1
7	011-0150	Tandem Drive Pump	1
8	011-0152A	Auxiliary Pump	1
9	010-0282	Exhaust Manifold	1
10	010-0326	Fan	1
11	010-0266	Belt	1
12	010-0253	Starter	1
13	010-0435	Alternator	1
14	021-0201	Air Cleaner Assembly	1
15	021-0202	Air Cleaner Clamp	1
16 (Not Shown)	010-0243	Kit Radiator	1

### Hydraulic Tank

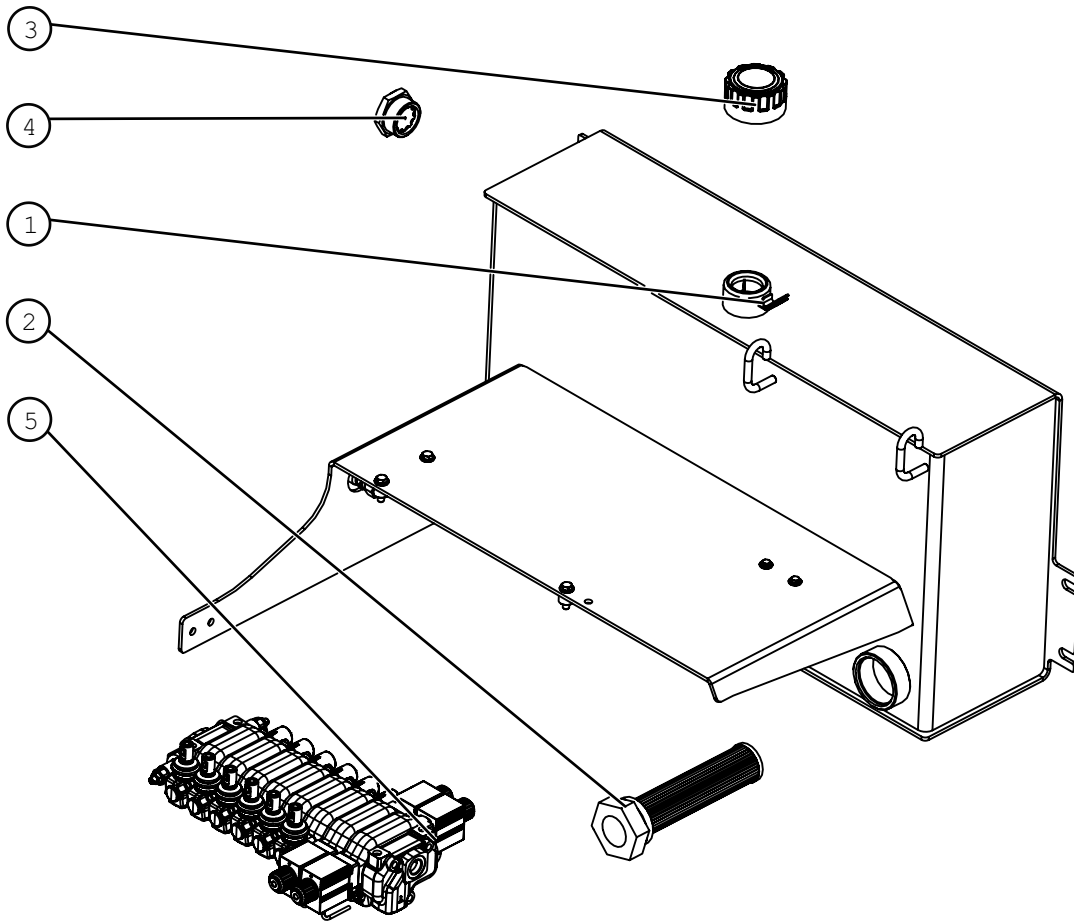

**Hydraulic Tank**

BOM ID	Part Number	Description	Quantity
1	092-410060	Hydraulic Tank Weldment	1
2	021-0186	Hydraulic Strainer	1
3	060-0069	Cap	1
4	060-0066	Sight Gauge	1
5	014-0475	9 Section Valve Bank	1
6 (Not Shown)	014-0475-2	Valve Section Handle	9

### Hydraulic Components

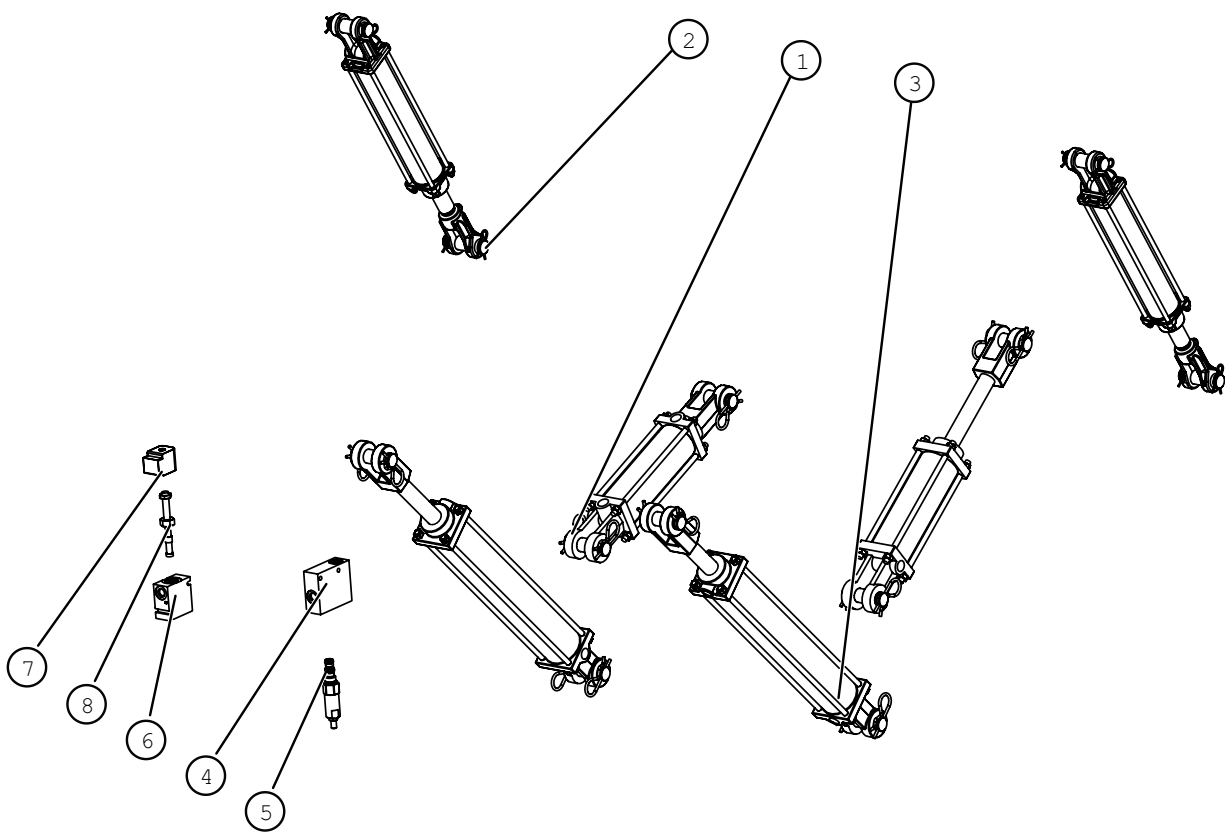

**Hydraulic Components**

BOM ID	Part Number	Description	Quantity
1	012-0005	Gate Cylinder	2
2	012-0065	Screed lift Cylinder	1
3	012-0070	Hopper Cylinder	2
4	017-0197	Valve Block	1
5	017-0198	Cartridge Valve	1
6	017-0241	Valve Body	1
7	017-0240C	Coil	1
8	017-0240V	Cartridge Valve	1

**Dash**

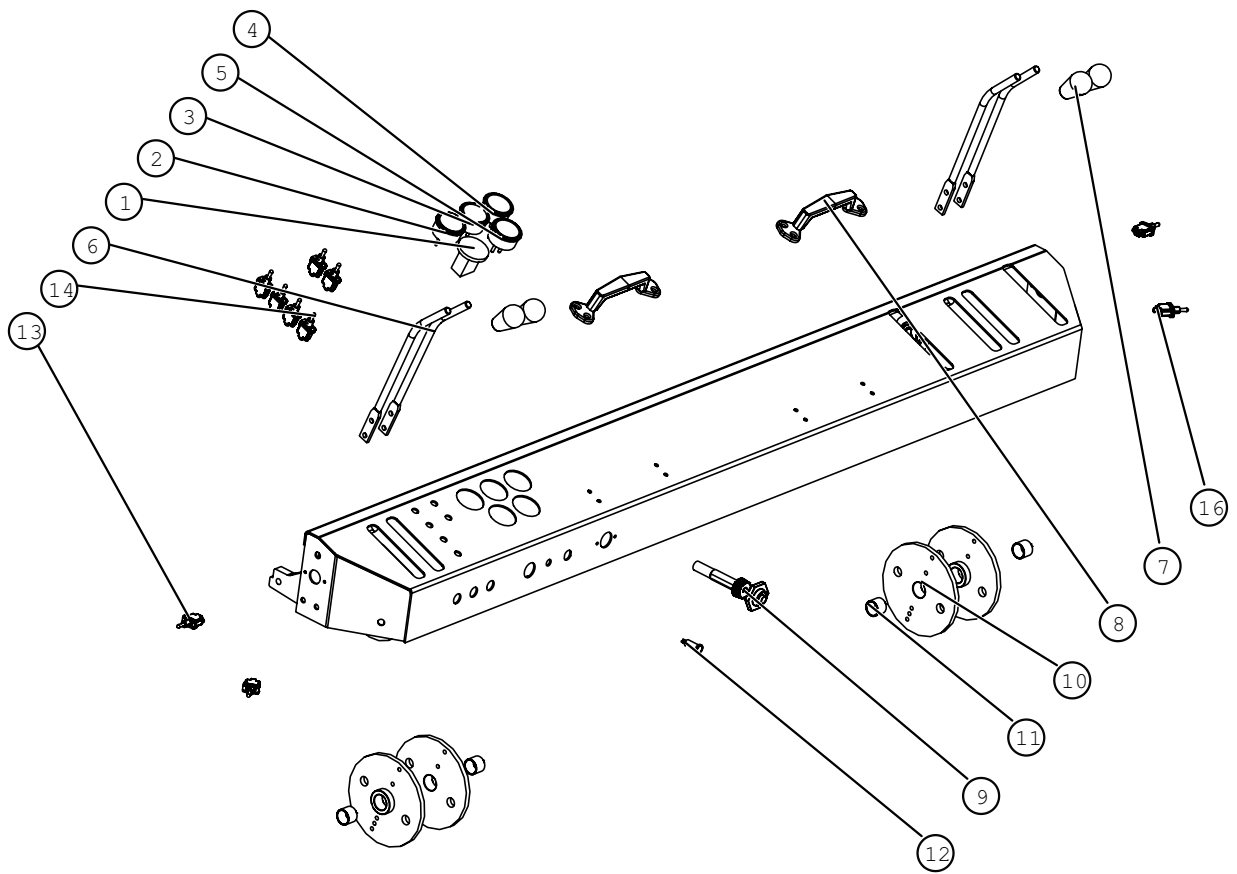

**Dash**

BOM ID	Part Number	Description	Quantity
1	020-0173	Gauge Hour Meter	1
2	020-0169	Gauge Volt Meter	1
3	020-0171	Gauge Oil Pressure	1
4	020-0172	Gauge Coolant Temp	1
5	020-0170	Gauge Fuel Level	1
6	093-0318	Drive Lever	4
7	050-0388	Knob	4
8	050-0205	Safety Handle	2
9	050-0347	Cable Throttle	1
10	093-100074	Gear Aluminum	4
11	018-0109	Brass Bushing	4
12	020-0140	Indicator Light	1
13	020-0405	Switch Toggle On/Off	7
14	020-0423	Switch, Horn	1
16	020-0083	Switch Auger Direction	2
17	020-0407 (Not shown)	Fuse block	1
18	093-100075	Gear 40 Tooth Nylon	4
19	020-0002 (Not Shown)	Switch Neutral Safety	2

### Main Screed

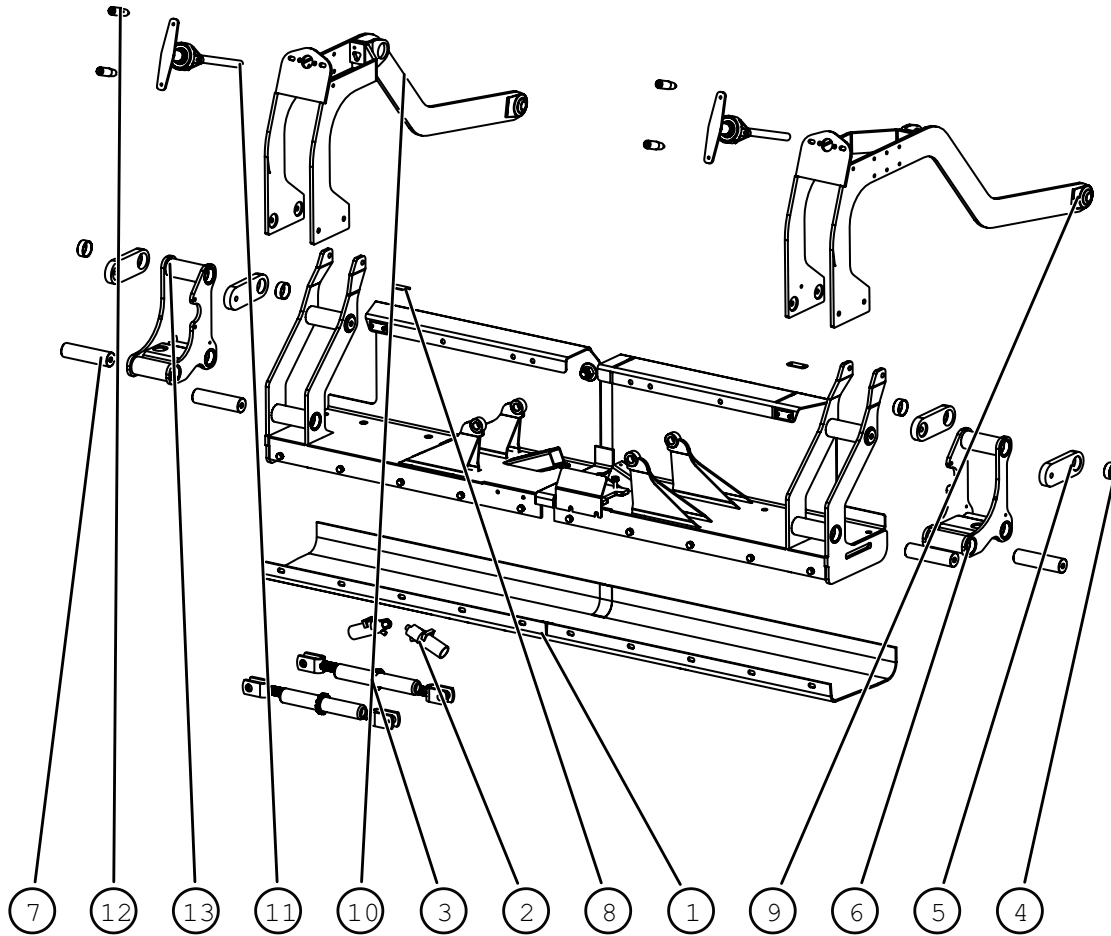



**Main Screed**

BOM ID	Part Number	Description	Quantity
1	111-200008	Screed Bottom	1
2	112-109290	Propane Burner	2
3	050-0147	Ratchet Jack	2
4	018-0098	Bushing	4
5	113-200016	Radius Arm	4
6	111-200012	Adjusting Link RH	1
7	113-200018	Pin	4
8	050-0415	Hose Clamp	2
9	112-200054	LH Screed Arm	1
10	112-200055	RH Screed Arm	1
11	111-200070	Screed Depth Adjustment	2
12	113-100427	Handle	4
13	111-20013	Adjusting Link LH	1
14 (Not Shown)	020-0667	Vibrator Electric	1



**Right Extension**

BOM ID	Part Number	Description	Quantity
1	112-200014	Extension Weldment RH	1
2	113-200082	Adjustment Plate	1
3	092-0022A	End Gate Weldment RH	1
4	111-104170	Ratchet Handle	2
5	111-201004	End Gate Adjustment Rod	2
6	112-201012	End Gate Threaded Rod	2
7	113-201016	Spacer	2
8	013-0096	Auger Motor	1
9	113-200072	Auger Motor Bracket	1
10	015-0154	Auger Sprocket	1
11	015-0045	Coupling Chain	1
12	092-0013	Auger RH	1
13	111-200080	Assembly Auger Bracket (includes bearing)	1
14	018-0105	Bearing	1
15	113-200030	Extension Wear Plate	1
16	113-200046A	Extension Burner Tube	1
17 (Not Shown)	020-0357A	Asphalt Material Switch	1
18 (Not Shown)	112-109290	Burner Propane	1
19 (Not Shown)	050-0269	Orifice	1



**Left Extension**

BOM ID	Part Number	Description	Quantity
1	112-200015	Extension Weldment LH	1
2	113-200082	Adjustment Plate	1
3	092-0021A	End Gate Weldment LH	1
4	111-104170	Ratchet Handle	2
5	111-201004	End Gate Adjustment Rod	2
6	112-201012	End Gate Threaded Rod	2
7	113-201016	Spacer	2
8	013-0096	Auger Motor	1
9	112-200072	Auger Motor Bracket	1
10	015-0154	Auger Sprocket	1
11	015-0045	Coupling Chain	1
12	092-0014	Auger LH	1
13	111-200080	Assembly Auger Bracket (includes bearing)	1
14	018-0105	Bearing	1
15	113-200030	Extension Wear Plate	1
16	113-200047A	Extension Burner Tube	1
17 (Not Shown)	020-0357A	Asphalt Material Switch	1
18 (Not Shown)	112-109290	Burner Propane	1
19 (Not Shown)	050-0269	Orifice	1

### Right Track Assembly

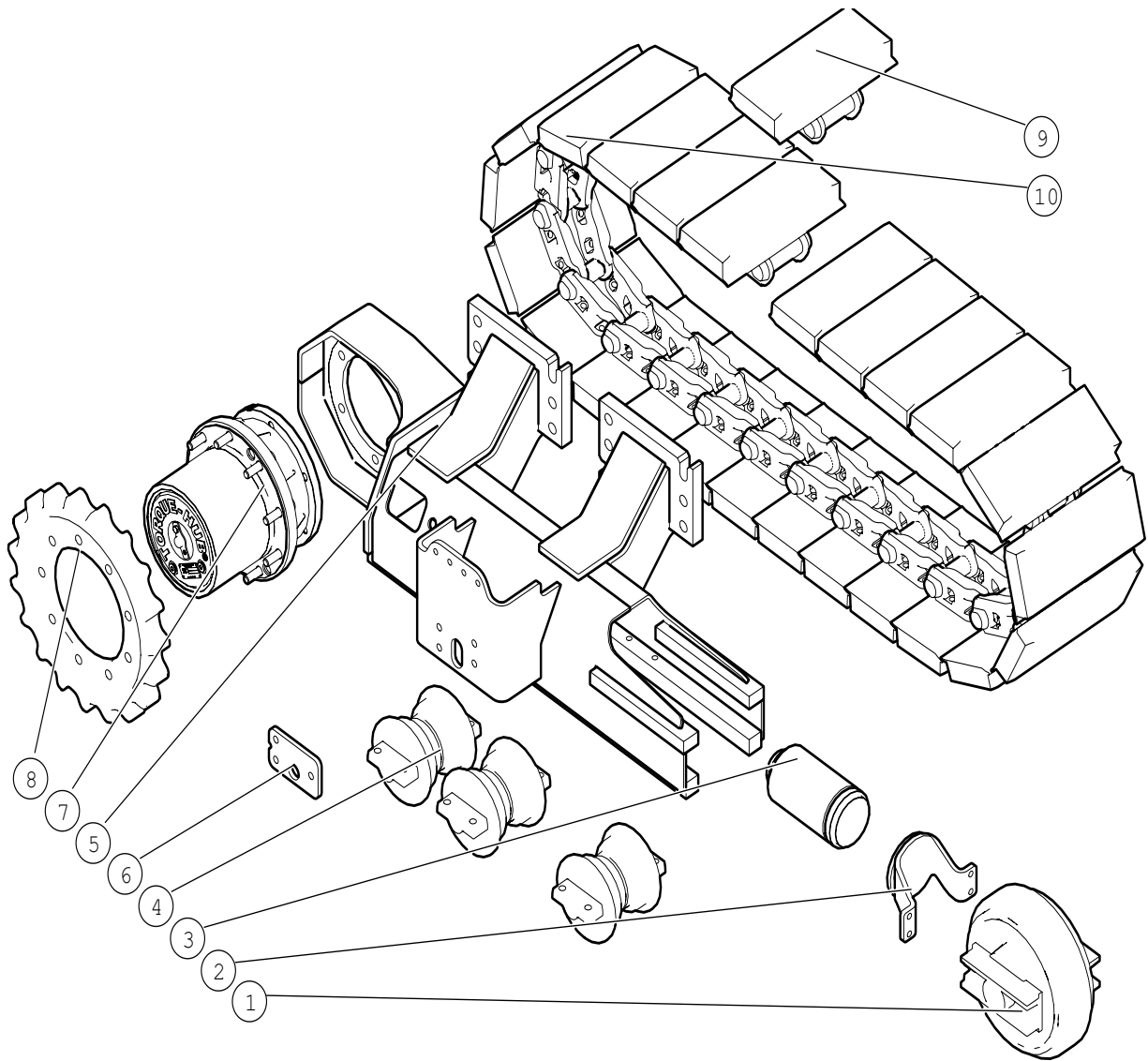

**Right Track Assembly**

BOM ID	Part Number	Description	Qty
1	050-0624	Track Idler Wheel	1
2	092-204524	Track Idler Yoke	1
3	012-0060	Track Tension Cylinder	1
4	050-0257	Track Roller	3
5	092-410500	RH Track Frame	1
6	093-204550	Screed Arm Mount Plate	1
7	016-0063	Planetary and Drive motor Assembly	1
8	015-0275	Drive Sprocket	1
9	050-0664EX	Track Pad Poly Urethane	25
10	050-0439	Complete Track Assembly	1
11 (Not Shown)	015-0276	Track Master Pin	1
12 (Not Shown)	030-0500	Bolt Track Pad	100
13(Not Shown)	030-0501	Nut Track Pad	100

### Left Track Assembly

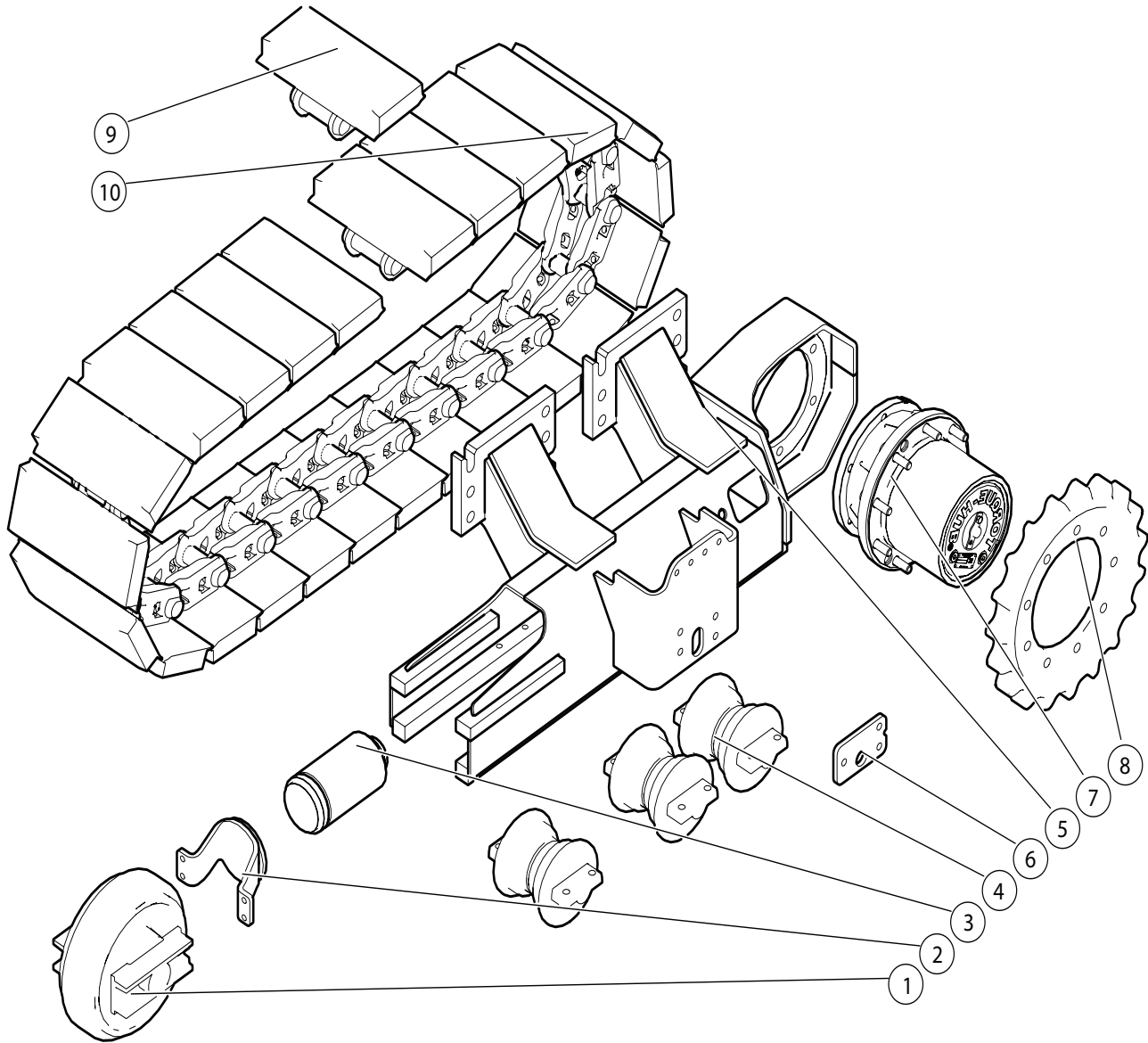



**Left Track Assembly**

BOM ID	Part Number	Description	Qty
1	050-0624	Track Idler Wheel	1
2	092-204524	Track Idler Yoke	1
3	012-0060	Track Tension Cylinder	1
4	050-0257	Track Roller	3
5	092-410501	LH Track Frame	1
6	093-204550	Screed Arm Mount Plate	1
7	016-0063	Planetary and Drive motor Assembly	1
8	015-0275	Drive Sprocket	1
9	050-0664EX	Track Pad Poly Urethane	25
10	050-0439	Complete Track Assembly	1
11 (Not Shown)	015-0276	Track Master Pin	1
12 (Not Shown)	030-0500	Bolt Track Pad	100
13(Not Shown)	030-0501	Nut Track Pad	100

**Propane Heating**

**No Exploded View  
Available**

**Propane Heating**

BOM ID	Part Number	Description	Quantity
1	020-0577	Screed Heat Control System Assembly	1
2	112-109290	Propane Burner	2
3	020-0562	Hot Surface Ignitor	4
4	090-0231	Hand Torch Assembly	1
5	130112	Control box (Enclosure only)	1
6	020-0564	Time Delay Relay	1
7	E0141	12v Relay	3
8	020-0405	Toggle Switch On/Off	1
9	020-0574	Indicator light	1
10	020-0574	Wire Harness	1
11	050-0049	Propane Regulator	1

Electrical Schematic

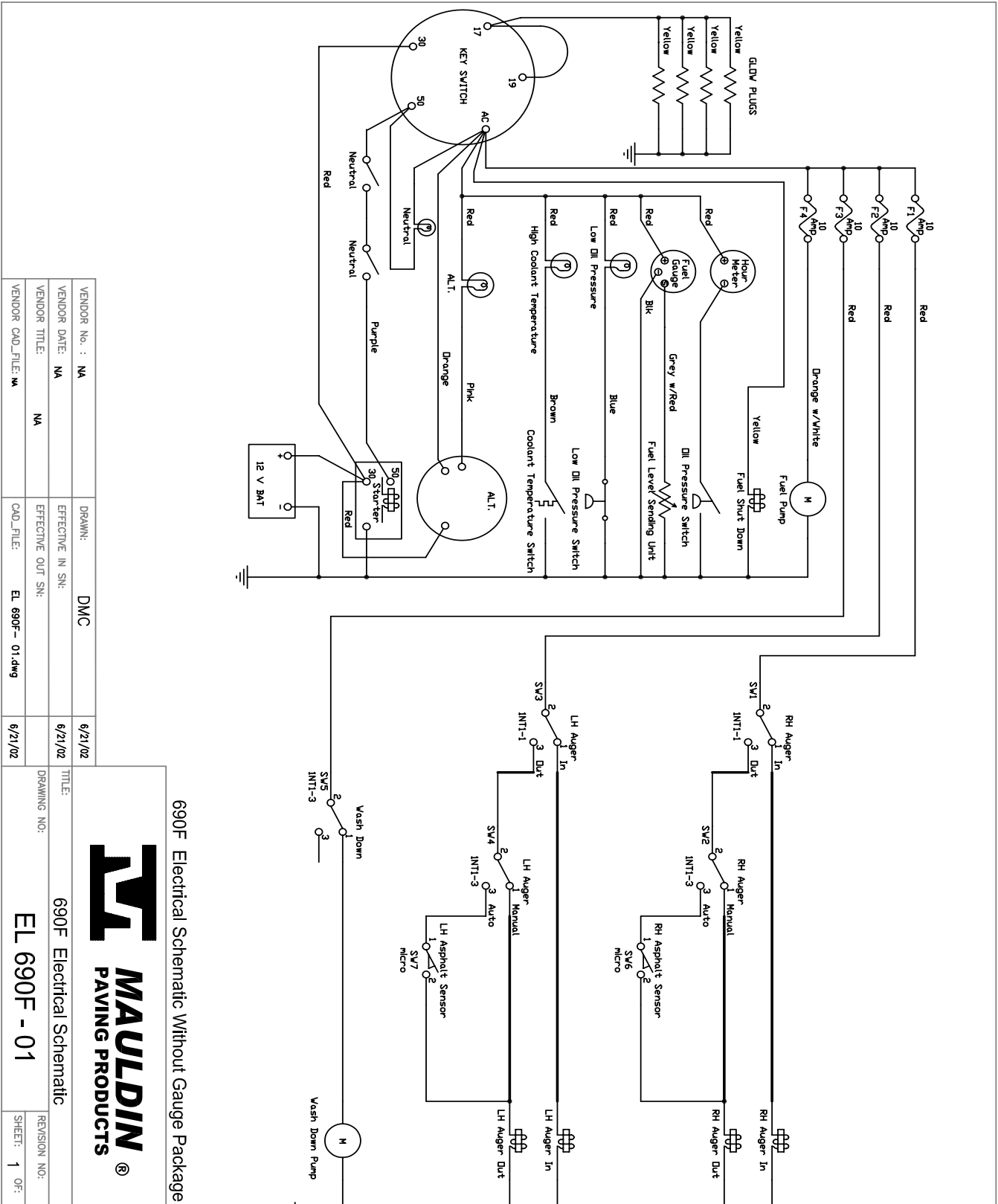

690F Electrical Schematic Without Gauge Package



690F Electrical Schematic

VENDOR No. : NA	DRAWN: DMC	6/21/02
VENDOR DATE: NA	EFFECTIVE IN SN: 6/21/02	
VENDOR TITLE: NA	EFFECTIVE OUT SN:	
VENDOR CAD_FILE: NA	CAD_FILE: EL_690F-01.dwg	6/21/02

TITLE: 690F Electrical Schematic	REVISION NO:
DRAWING NO: EL_690F - 01	SHEET: 1 OF:

Propane Heat Electrical Schematic

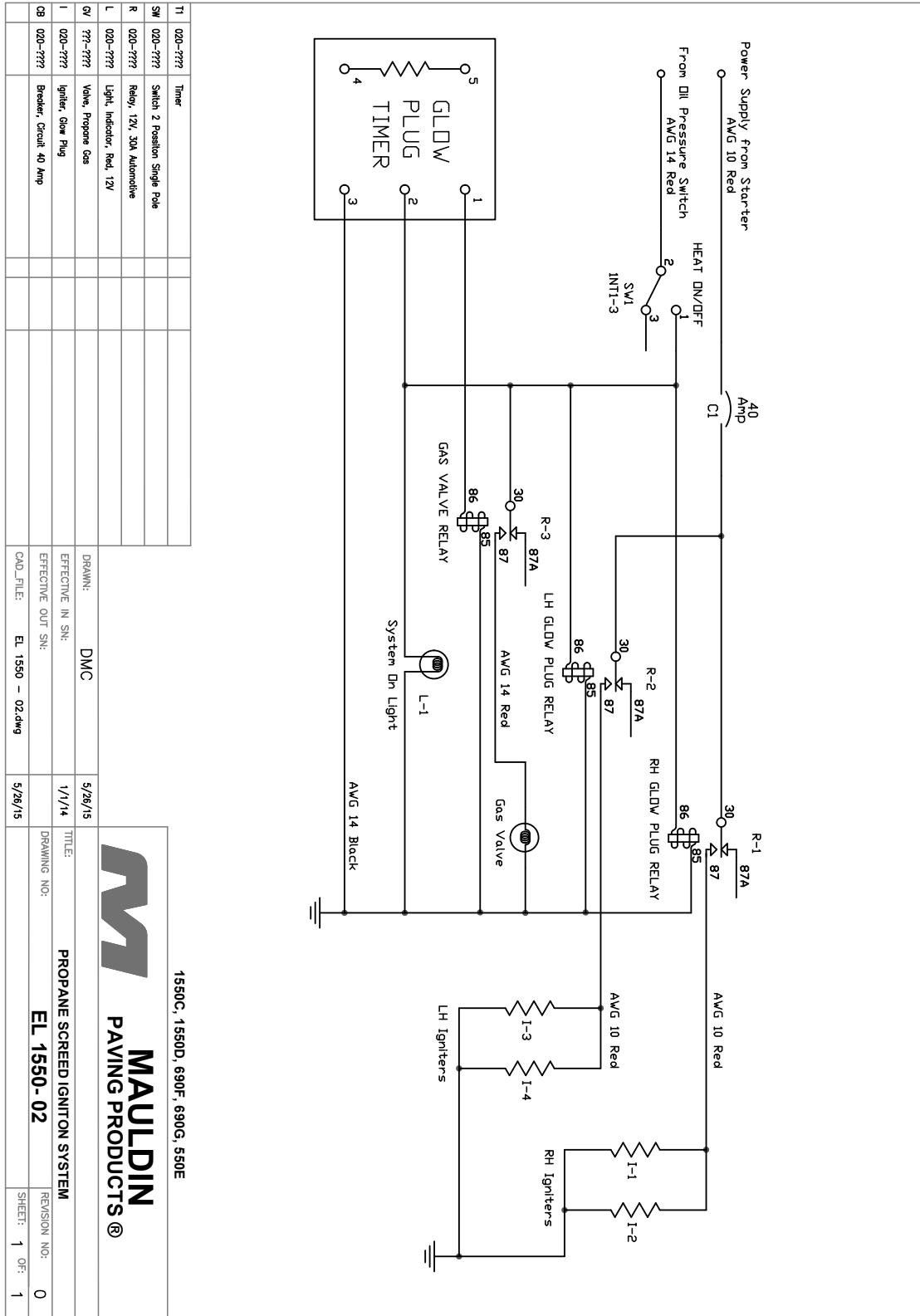

Hydraulic Schematic

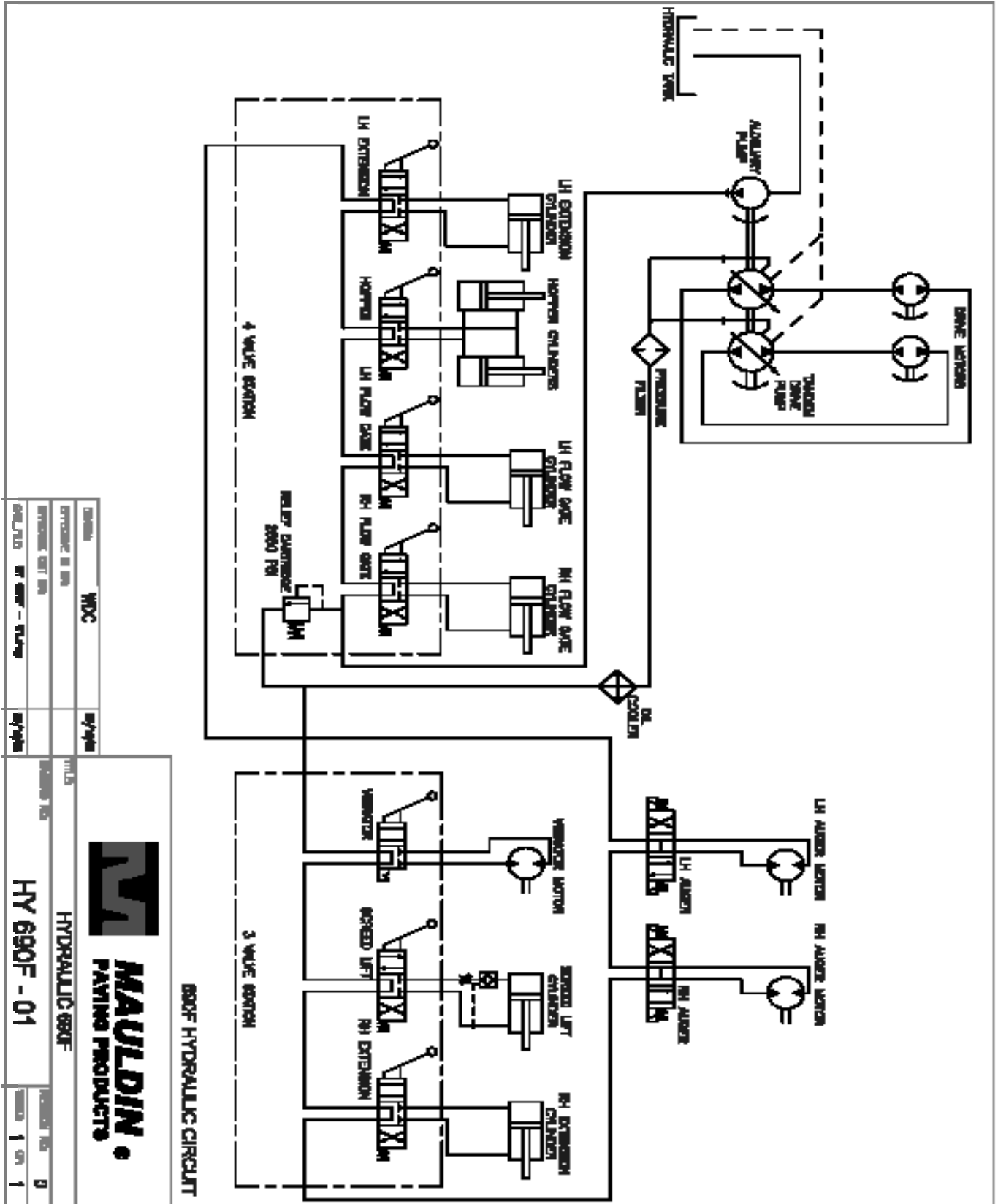



## **CALDER BROTHERS CORPORATION**

### **(LIMITED) PRODUCT WARRANTY**

Calder Brothers Corporation warrants that the Paver, Roller, Tank or Grader under this program will be free from defects in material and workmanship for a period of (12) twelve months from the date of installation. Written notice of any claimed defect must be given to Calder Brothers Corporation within the warranty period and within (30) thirty days after such defect is discovered. Liability under this warranty is limited to replacing or repairing at Calder Brothers Corporation election, any part or parts deemed defective after examination by Calder Brothers Corporation or an Authorized Service Representative via prepaid transportation for which is found to be defective, will be repaired or replaced and returned to the customer via prepaid surface transportation within the United States. Should any part be found not defective, inspection and handling may be charged to the customer by Mauldin or an Authorized Service Representative.

#### **EXCLUSIONS:**

This warranty does not apply to routine wearable parts of the Mauldin machine such as seals, points, plugs, hoses or similar items. This warranty does not extend to any machine or part replaced or repaired under this warranty. This warranty does not cover any repair or replacement labor or any part of parts found defective after examination by Mauldin or an Authorized Service Representative. This warranty does not apply to defects caused by casualty or unreasonable use, including faulty repairs by others and failure to provide reasonable and necessary maintenance.

THIS WARRANTY SET FORTH HEREIN IS IN LIEU OF AND EXCLUDES ANY AND ALL OTHER WARRANTIES, EXPRESSED OR IMPLIED, ARISING BY OPERATION OF LAW OR OTHERWISE, INCLUDING, BUT NOT LIMITED TO, ANY IMPLIED WARRANTY OF MERCHANTABILITY OR FITNESS FOR A PARTICULAR PURPOSE, AND CUSTOMER WAIVES ANY OBLIGATION OF LIABILITY OF MAULDIN ARISING IN TORT OR STRICT LIABILITY IN TORT, OR FOR LOSS OR USE, REVENUE OR PROFIT WITH RESPECT TO MAULDIN MACHINE AND/OR PARTS FOR ANY LIABILITY OF CUSTOMER TO ANY THIRD PARTY, OR FOR OTHER DIRECT, INCIDENTAL OR CONSEQUENTIAL DAMAGES.

**I have read and fully understand the warranty policy above.**

\_\_\_\_\_  
Customer

*CALDER BROTHERS CORPORATION*

\_\_\_\_\_  
Witness