



OPERATIONS MANUAL MODEL 650

Machine Serial Number: _____

Specification Number: _____

Engine Serial Number: _____

SOLD & SERVICED BY:

A large, empty rectangular box with rounded corners and a drop shadow, designed for a signature. The box is oriented vertically and has a small, grey, circular icon in the top right corner, resembling a scroll or a document edge.

TABLE OF CONTENTS

SECTION	ITEM	PAGE
1.0	Daily Start-up Checklist	3
2.0	Important Safety Information	4
3.0	Service Warning	4
4.0	Paver Operation	5
4.1	Starting The Paver	6
4.2	Driving Techniques	6
4.3	Steering Tension Adjustment	6
4.4	Two Speed	6
5.0	Material Feed Operation	7
5.1	Automatic Material Feed Setups	7
5.2	Manual Material Feed Setups	7
6.0	Freedom Screed™	8
6.1	Screed Heating System	8
6.2	Crown Setting: Freedom Screed™	9
6.3	Extension Setting: Freedom Screed™	10
6.4	Setting the Freedom™ to Pave	11
7.0	Drive System Adjustments	12
7.1	Rubber Tire: chain system tension procedure & settings	12
7.2	Crawler Track Tensioning procedure & settings	12
8.0	Fluid Capacities & Recommendations	13
8.1	Recommended Fuels & Alternative Fuels	13
8.2	Engine Coolant	13
8.3	Air Intake Cleaning WARNING	13
9.0	LUBRICATION & SERVICE PROCEDURES	13
9.1	Air Filters	13
9.2	Battery	14
9.3	Engine & Engine Filters	15
9.4	Hydraulic System	16
9.5	Troubleshooting Guide	17
9.6	Component Removal & Installation	20
9.7	Recommended Preventive Maintenance Intervals	21
10.0	Warranty	22

Daily Start-up Checklist

1. Check Fluid Levels:
 - a. Engine Oil
 - b. Engine Coolant
 - c. Hydraulic Oil
 - d. Wash Down fluid
2. With the key switch in the "ON" position:
 - a. Check Engine Fuel Level
 - b. Turn on wash down pump and verify operation, turn off when complete.
 - c. Verify proper operation of engine gauges or indicator lights.
3. Turn Key switch back to "OFF" position.
4. Remove asphalt from all mechanical moving surfaces
5. Remove asphalt from all screed burner heating areas
6. Check Propane Tank level.

Perform All Propane Testing In A Well Ventilated Area Only!

FAILURE TO COMPLY MAY RESULT IN DAMAGE TO EQUIPMENT AND / OR INJURY OR DEATH TO PERSONNEL.

7. Verify that **ALL** propane valves are in the closed position.
8. Pressurize the propane system by opening the master valve located on the propane tank.
9. With system pressurized, listen for leaks. Run hand over all propane fittings to feel for leaks. If any leaks are detected, **DO NOT OPERATE UNTIL THEY ARE REPAIRED!**
10. Check pressure regulator is set to 4 – 6 PSI on Freedom Screed.
 - a. If regulated pressure is too high, open **main screed valve only** allowing gas to escape.
 - b. Adjust regulator to 4 – 6 PSI on Freedom Screed.
 - c. Close main screed valve.
11. Close the master valve located on the propane tank.
12. Verify & if necessary follow procedure to set screed.
13. Perform a machine walk around looking for:
 - a. Any signs of physical damage
 - b. Any signs of a leak, (fuel, engine oil, hydraulic oil, engine coolant)
 - c. Welded steel junctions
 - d. Hydraulic cylinder pins all secure

IMPORTANT SAFETY INFORMATION

Most accidents involving paver maintenance are caused by failure to observe basic safety rules or precautions. An accident can often be avoided by recognizing potentially hazardous situations before an accident occurs.

Read and understand all safety precautions and warnings, before operating or performing lubrication and maintenance on this paver.

WARNING: IMPROPER OPERATION, LUBRICATION OR MAINTENANCE OF THIS PAVER CAN BE DANGEROUS AND COULD RESULT IN INJURY OR DEATH.

WARNING: DO NOT OPERATE THIS PAVER UNTIL YOU READ AND UNDERSTAND THE INSTRUCTIONS IN THE **OPERATION SECTION** OF THIS MANUAL.

WARNING: DO NOT PERFORM ANY LUBRICATION AND MAINTENANCE ON THIS PAVER UNTIL YOU READ AND UNDERSTAND THE INSTRUCTIONS IN THE **MAINTENANCE SECTION** OF THIS MANUAL.

WARNING: DO NOT OPERATE BURNERS ON SCREED FOR MORE THAN TEN OR FIFTEEN MINUTES AT A TIME.

SERVICE WARNING

General

Operating personnel must perform service checks regularly to be sure systems are in good operating condition. If abnormal conditions are detected, inform maintenance personnel immediately.

Check all systems for proper operation. Check chassis and all components for physical damage and security of all fasteners and connectors.

PAVER OPERATION SECTION

Prior to starting the following procedures must be completed.

1. Check engine oil level
2. Check engine coolant level
3. Check hydraulic oil level

The paver controls for the 690-F consist of two operators stations. The photograph below will introduce the control panels as well as familiarize you with the terminology associated with them. You will want to refer back to this page as you read through the manual.

MAIN CONTROL PANEL

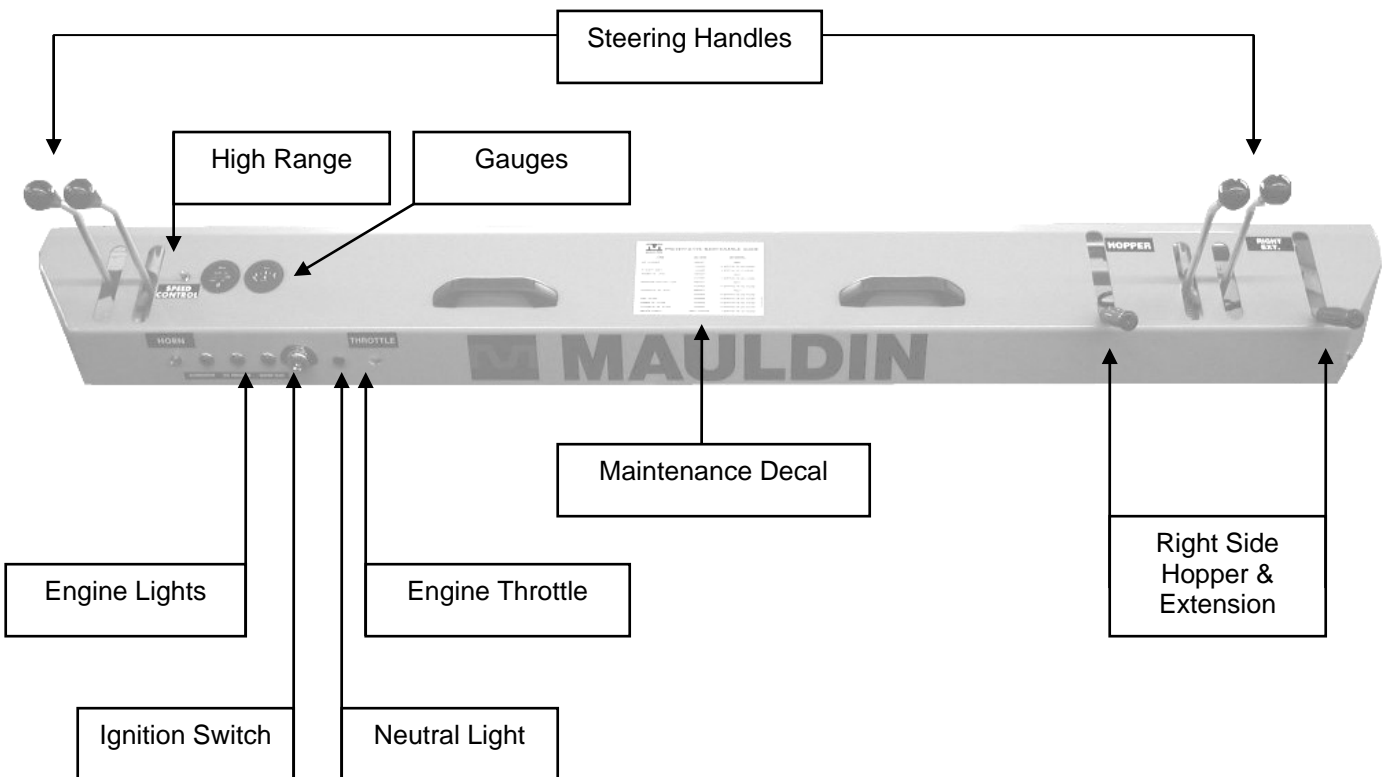

STARTING THE PAVER

1.0 STARTING

To start the paver first check to make sure the forward and reverse levers are in the neutral position. The paver will not start if the red indicator light is not “ON” indicating a neutral position.

- Turn key switch to the “ON” position, adjust steer handles until red indicator light is “ON”
- Turn key switch back to the left, position “PRE-HEAT” count to 5
- Turn key switch to “START”.
 - *If engine does not start quickly, repeat the PRE-HEAT step*
- Adjust engine RPM as needed for smooth idle.

CAUTION: Do not Pre-heat more than 5 seconds at a time, or Glow Plug failure will occur.

CAUTION: Do not use any starting fluid, or **engine warranty will be VOID!!!!**

2.0 DRIVING

The paver will move forward by pushing both levers forward and will move backwards by pulling the levers back. Steering a course is accomplished by adjusting the speed of one handle relative to the other. ***HINT - to make driving easy, push both handles forward to desired speed, then use only one handle to fine-tune your direction.***

3.0 STEERING TENSION

The steer handles can be adjusted for operator preference on tension, (or drag). In a loose position the handles will spring return to neutral, this requires constant pressure on the handles by the operator. Tension can be added to the point were the handles are locked and cannot be moved. The ideal setting is somewhere in-between were the handles have enough tension to stay in the position the operator chooses, but not so stiff as to produce fatigue.

To adjust tension: loosen or tighten the nut located at the center of the aluminum discs were the handles are attached.

4.0 TWO SPEED

CAUTION: INJURY/OR DAMAGE MAY OCCUR: When switching to high range, bring paver to a stop before switching. To engage from low to high flip the High range switch up.

MATERIAL FEED OPERATION

The 690-F allows you to configure the auger operation of the paver for both an Automatic mode and a Manual mode. Use the automatic setting whenever possible to increase the useful life of the feed augers, and to maintain a more consistent “Head of Material” in front of the screed. In either mode the lower selector switch can be set to “IN” for reverse material flow.



SETUP *Each side of the paver must be set independently.*

AUTOMATIC AUGER FEED OPERATION

- 1.0 Go to the LH operators station
- 2.0 Locate the switch labeled:
“AUTO – MAN”
- 3.0 Set the switch to “AUTO”
- 4.0 Locate the switch labeled:
“OUT – LEFT AUGER – IN”
- 5.0 Set the switch to the “OUT”
- 6.0 Adjust height of switch by end gate to control size of the head of material

MANUAL AUGER FEED OPERATION

- 1.0 Go to the LH operators station
- 2.0 Locate the switch labeled:
“AUTO – MAN”
- 3.0 Set the switch to “MAN”
- 4.0 Locate the switch labeled:
“OUT – LEFT AUGER – IN”
- 5.0 Set the switch to the “OUT”
- 6.0 Change this switch from the “LEFT AUGER” position to the “OUT” and back to the “LEFT AUGER” position, to operate.

SCREED HEATING SYSTEM

The new Freedom Screed ® has one burner in each extension and two main screed burners. The proper way to light the burner system is the following procedure.

1. Make sure all shutoff valves are in the off position and lighting wand is off.
2. Fully extend the extensions.
3. Turn on gas at tank, and set gauge pressure between at 4-6 p.s.i.
4. Light the lighting wand
5. Turn on the gas to the extensions. One at a time.
6. Quickly point the lighting wand at flap style door towards the bottom inboard zone of the screed extensions to ignite the burner.
7. The extension burners will have changed from a hissing noise to a roaring noise confirming ignition.
8. Repeat for other side. After extension burners are lit, turn on gas to the main screed.
9. Quickly light each of the burners on the main screed.

Only use burners for 10 - 15 minutes at any given time. Damage to screed plate will occur.

***WARNING:* NEVER USE SYSTEM WITHOUT DIRECT CONSTANT SUPERVISION
PERSONAL INJURY OR DEATH MAY RESULT.**

***WARNING:* EXCESS GAS ACCUMULATING BEFORE LIGHTING BURNERS MAY
CAUSE AN EXPLOSION RESULTING IN PERSONAL INJURY OR DEATH.**

FREEDOM SCREED CROWN SETTING

- 1a. On a flat surface, find the null position of the screed depth handles by adjusting them until they are free and not in tension.
- 1b. Run a string across the leading edge (front) of the main screed bottom, as close as possible to the bullnose of the screed plate, and adjust the forward ratchet jack until there is a slight gap (approximately 1/16" or less) between the screed plate and the string.

String MUST be on the flat portion of the screed, not on the radius portion

2. Place the string across the back of the main screed bottom, near the trailing edge (rear) curvature of the screed plate, and adjust the rear ratchet jack until the screed plate just touches the whole length of the string. Pull the string away, at one end, and bring it back to verify that it contacts the entire length at the same time.

String MUST be on the flat portion of the screed, not on the radius portion

3. Place the string across the front of the screed bottom and double check the gap between the screed bottom and the string. Re-adjust the forward ratchet jack as necessary to obtain the 1/16" or less gap between the string and screed plate.
4. Place the string across the rear of the screed bottom and double check the gap between the screed bottom and the string. Re-adjust the rear ratchet jack as necessary to verify the screed plate just touches the whole length of the string.
5. Repeat steps 3 and 4 until no adjustment is required.

Crown Definition:

Manipulation of the ratchet jacks to deflect the screed bottom, in order to produce the desired mat texture and profile.

Optimum performance achieved when screed has very minor positive crown.

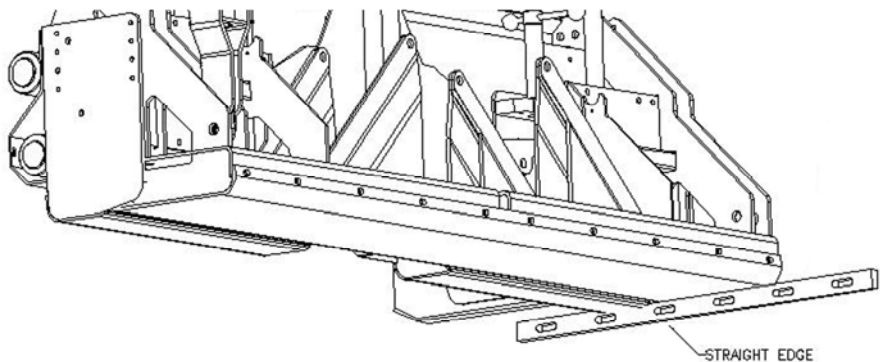

FREEDOM SCREED EXTENSION SETTING

6. **(See Figure 6.1)** With the extensions completely closed, adjust the screed depth handle until the extension screed plate rear curved edge just touches a straight edge held against the main screed bottom at the outside edge, oriented in forward to rearward direction.
7. **(See Figure 7.1)** Next, with the extensions completely closed, run a string across the entire trailing edge, (rear), width of the screed extension bottoms. Release turnbuckle jam nut and adjust turnbuckles until there is a slight gap (approximately 1/16" or less) between the screed extension bottoms and the string.
8. **(See Figure 7.1)** Lock all ratchet jacks and turnbuckle lock nuts to prevent movement during paving operations.

Figure 6.1

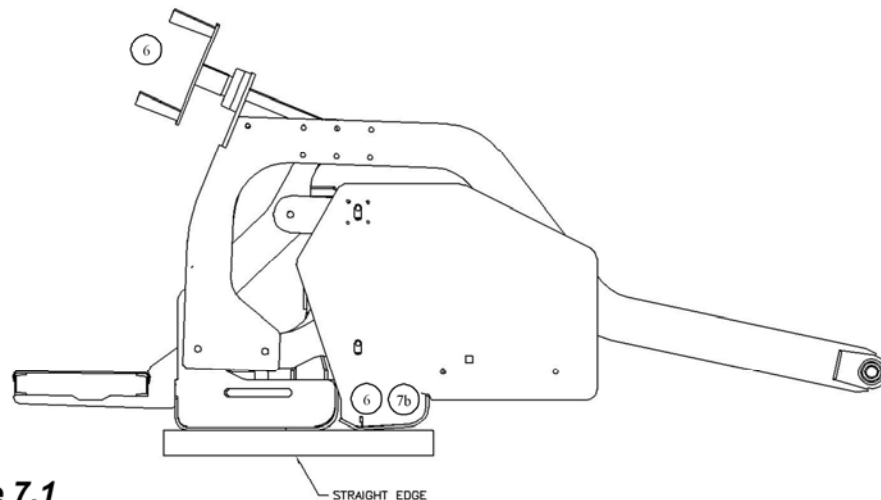
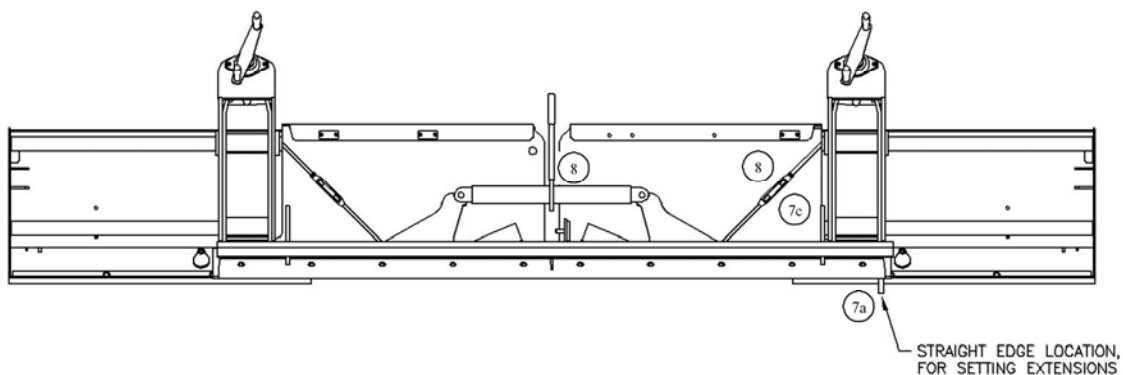

Figure 7.1



SETTING THE FREEDOM® TO PAVE

The procedure on the previous page was set on your Freedom® Screed before leaving the factory. It is strongly recommended that before initial start up you follow this procedure and check the settings.

BEFORE YOU PAVE WITH THE FREEDOM®

Screed must be elevated a distance equal to the desired mat depth plus enough extra height to allow for compaction. To achieve this, the most popular methods are; an asphalt pad and starting blocks.

- Starting Blocks – a 2.5” thick starting block is a good starting block for a finished mat of 2 inches
- Compacted Asphalt Pad – a starting block equal to the amount of compaction will be required.
- Non-Compacted Asphalt Pad – just lower the screed fully onto pad, no starting block required.

Starting blocks should be at least as long as the front to rear dimension of the screed plate. They should be placed lengthwise in the direction of travel, directly below the screed depth cranks.

Nulling The Screed & Setting Angle of Attack

This is the adjustment of the screed to the perfectly flat position on either the starting blocks or the asphalt pad. To null the screed follow this procedure:

1. Lower screed **completely** onto starting surface, (blocks or pad).
2. Rotate the cranks until you locate the position of free movement. This is a limited area where the depth cranks will both rotate freely in either direction. This is the nulled position.
3. Rotate thickness screw two full rotations, (in the thicker direction). Start paving and make adjustments as required.

DRIVE TIRE - CHAIN ADJUSTMENTS

1. Remove chain covers.
2. Loosen bolts on wheel bearings slightly.
3. Loosen chain adjusters on each side of drive wheel axles.
4. Using a $\frac{3}{4}$ " wrench, tighten chains to approximately $\frac{3}{4}$ " slack depression. Align sprockets in turn by swapping sides of wheel.
5. After alignment is finished, tighten bolts on wheel and tighten chain adjusters opposite drive side.
6. Check chain again for $\frac{3}{4}$ " slack depression.
7. Replace chain covers.

CRAWLER TRACK - CHAIN ADJUSTMENTS

1. Idler sprockets should be greased daily.
2. With a 1" wrench, (or crow bar), tighten track through side access.
3. Track should be adjusted so that the top hangs level.

DO NOT OVER TIGHTEN!

4. Check bearings annually.

Fluid Capacities and Recommendations

Fluid	Capacity	Recommendation
Engine oil	1.77 U.S. gal.	<ul style="list-style-type: none"> • CD grade lubricating oil or higher. 32°F - 77°F use SAE20 or (SAE10W-30/40). • Above 77°F use SAE30 or (SAE10W-30/40). • If operating below 32°F SAE10W or (SAE10W-30/40).
Engine Coolant	1.32 U.S. gal.	Permanent type "PT". Use a pure water to anti-freeze ratio of: 50% water to 50% Anti-freeze. Machine Storage below -10°F, (-23°C) should consult the engine manual or an engine specialist.
Diesel	13 U.S. gal.	No. 2-D climatized diesel. In extreme cold temperatures, use a winter blend.
Hydraulic	17.5 U.S. gal.	High quality anti-wear hydraulic oil (original equipment, HVI 46 B.P. Energol).
Grease	As required	N.G.L.I. consistency #2, high temperature anti-friction, bearing lubricating grease.

Lubrication and Service Procedures

Air Filters

IMPORTANT: *Service the engine air filters only when the air cleaner service indicator indicates the need. Excessive service will cause premature wear.*

1. Engine Element - replace

IMPORTANT: *Do not attempt to clean element using an air nozzle. Do not strike element on a hard surface. Either action will damage the element.*

2. Engine Safety Element

IMPORTANT: *Do not remove safety element under heavy dust or blowing conditions (in the field). Even slight amounts of dust entering the engine can lead to premature wear.*

- a. Inspect safety element for contamination and physical damage.

- b. Remove canister end cap to gain access to element.

IMPORTANT: *When safety element is dirty, it should be replaced. Do not attempt to clean.*

Battery

CAUTION: BATTERY ELECTROLYTE IS A CAUSTIC ACID. KEEP IT AWAY FROM SKIN AND EYES. IF CONTACT OCCURS, FLUSH THE AFFECTED AREA WITH LOTS OF WATER.

CAUTION: DISCONNECT GROUND CABLE FROM THE NEGATIVE BATTERY POST BEFORE ATTEMPTING TO SERVICE OR REMOVE BATTERY.

1. Removal

- a. Disconnect ground (negative) cable from battery (-) terminal.
- b. Remove the battery retainer bracket.
- c. Disconnect positive cable from battery (+) terminal.

2. Cleaning

- a. Remove battery, following correct procedures.
- b. Thoroughly clean terminals with a battery-cleaning tool.
- c. Mix to paste solution of baking soda and water and apply to battery and terminals.
- d. Rinse battery and machine area near battery liberally with water.

3. Installation

- a. Clean battery, follow correct procedures.
- b. Be certain battery area is clean and clear of debris.
- c. Install battery and retainer bracket.
- d. Connect positive (+) cable to terminal.

CAUTION: DO NOT CONNECT NEGATIVE (GROUND) TERMINAL FIRST. ARCHING CAN OCCUR, POSSIBLY CAUSING SEVERE BURNS AND / OR BATTERY EXPLOSION.

- e. Connect negative (-) terminal.

4. Charging

- a. Connect charger leads to proper battery terminals then precede according to charger manufacturer's instructions.

5. Storage

- a. Remove and clean battery, following correct procedures.
- b. Bring battery to full charge, following charger manufacturer's instructions.
- c. Store in a cool dry place where there is no possibility of freezing.

NOTE: Check battery every 30 days during storage and return to full charge if necessary.

Engine and Engine Filters

1. Initial Break-In

Proper break-in procedures are a must to realize maximum engine power output and longest engine life. Engine should show noticeable power gain through the first 30 hours service. Power gain will continue until approximately 200 hours if properly broken-in.

IMPORTANT: Do not operate engine above 3/4 throttle for the first 25 hours.

IMPORTANT: Do not 'lug' engine during the break-in period.

IMPORTANT: Replace the original oil and oil filters after the first 20 hours of operation.

2. Fuel Filters

Both fuel filters are disposable.

CAUTION: BOTH DIESEL FUEL AND GASOLINE ARE HIGHLY FLAMMABLE AND EXPLOSIVE UNDER CERTAIN CONDITIONS. DO NOT SMOKE OR ALLOW SPARKS OR OPEN FLAME WHEN HANDLING.

a. To Change:

- i. Stop engine. Wait 15 minutes for engine and surrounding parts to cool before proceeding.
- ii. Unscrew and discard existing filters.
- iii. Fill new filter with clean fuel.
- iv. Lightly coat the seal ring with oil, then screw on filter until seal meets flange.
- v. Tighten an additional 1/2 to 3/4 turn by hand.

IMPORTANT: Do not over tighten.

b. Oil and Filter Changing:

- i. Stop engine. Wait 15 minutes for engine oil to cool before proceeding.
- ii. Drain crankcase.
- iii. Unscrew and discard existing filters.
- iv. Fill new elements with fresh oil.
- v. Lightly coat the seal rings with oil, and then screw on filters until seals meet flanges.
- vi. Tighten an additional 1/2 to 3/4 turn by hand.

IMPORTANT: *Do not over tighten.*

- vii. Fill crankcase to correct level.
- viii. Start engine and run at low idle. Have an assistant visually check seal areas for leaks.
- ix. Stop engine. Wait a few minutes, and then check engine oil level once again.

Hydraulic System

1. Hydraulic Fluid Change

- a. Stop engine. Allow system pressure to drop and remove filler cap.
- b. Remove suction hose and drain into appropriate container for disposal.
- c. Remove and clean hydraulic filter screen assembly.
- d. Remove hydraulic returns filter. Replace filter element and reinstall.

CAUTION: DO NOT OVER APPLY SILICON GASKET MATERIAL ALLOWING SURPLUS TO ENTER HYDRAULIC SYSTEM.

- e. Replace fluid to approximately 1" from top of reservoir. Operate machine and recheck level.
- f. Check visually for oil leaks.

NOTE: *Each paver should be thoroughly inspected after each use and during maintenance cycle for:*

1. Tightness of mounting bolts and attaching hardware on bearings, couplings, frame, etc.
2. Leaks, cracks and loose electrical and fluid fittings.
3. Malfunctioning indicators or controls.
4. Worn or damaged tires, tracks or track pads.
5. Cleanliness.

TROUBLESHOOTING

1. General

Proper troubleshooting begins with an organized approach to the problem at hand. Begin with investigation of the most probable cause, following the guidelines below.

- Study the problem thoroughly before taking action.
- Did warning signs precede the problem? If so, what were they? What would they indicate?
- Is scheduled maintenance current on all parts and systems involved?
- Has similar trouble occurred before? What action was taken at that time?
- Can engine be operated without further damage?

CAUTION: IF RUNNING INSPECTION MUST BE MADE, GET ASSISTANCE. OPERATOR SHOULD REMAIN AT MACHINE CONTROLS THROUGHOUT INSPECTION. MAKE SURE TRANSMISSION IS IN NEUTRAL POSITION.

- Check the most convenient things first.
- Don't begin major work before checking all other possibilities.
- Reconsider all known facts and clues before proceeding to more in-depth work.
- Correct the basic cause.
- Remember, failure of a certain part may be caused by malfunction of another part or system.

2. Use of Schematics

The parts manual incorporates hydraulic schematic diagrams formatted for ease of use by maintenance and for the training of personnel.

3. Troubleshooting Chart

The troubleshooting chart lists problems, which might be encountered in the operation of the vehicle. The remedies listed may direct the repairman to a possible faulty component.

WARNING: THE TROUBLESHOOTING CHART AND PROCEDURES OUTLINED IN THIS SECTION SHOULD NOT BE ATTEMPTED BY OTHER THAN EXPERIENCED MECHANICS OR PERSONNEL UNDER THE DIRECT SUPERVISION OF AN

EXPERIENCED MECHANIC. FAILURE TO COMPLY MAY RESULT IN DAMAGE TO EQUIPMENT AND / OR INJURY OR DEATH TO PERSONNEL.

A. Engine

For engine troubleshooting see charts indicating faults and recommended repair procedures, refer to Manufacturer's Operation and Maintenance Manual.

If the particular problem is not covered or you are unsure of what steps to take, contact your dealer for assistance.

B. Transmission

1. Paver fails to move under power.

- Inadequate oil level in hydraulic reservoir
- Control cable broken or loose
- Inadequate oil flow through transmission suction filter
- Driveline mechanical failure

2. Paver moves in neutral

- Stroke control adjustment
- Control cable damage

C. Electrical System

Engine Status	Voltmeter Reading	Indicates	To Correct
Running	13.5 - 14 Volts	Normal Condition	
Running	Less than 13.5 or more than 14 Volts	Alternator or Regulator Malfunction	Contact Dealer
Won't Start	12 - 12.5 Volts	Weak battery	Charge
Won't Start	Less than 12 Volts	Weak battery or Defective Cell	Charge or Replace
Stopped	Excessive current Draw	Short Circuit	Inspect System

D. Hydraulic System

Thoroughly review description of hydraulic system.

Use logical steps to determine cause of malfunction.

Identify the function or functions that require troubleshooting.

If possible, trace malfunction to source: pump, control, motor or cylinder.

Determine if pressure or volume is inadequate for function as specified:

Hydraulic System Pressures

Auxiliary circuits, gear pump	2800 p.s.i.
Main circuit, hydrostatic pumps	4350 p.s.i.

Hydraulic System Flows

Auxiliary circuits, gear pump	10 g.p.m.
Main circuit, hydrostatic pumps	13 g.p.m. each

(Flow determined at engine r.p.m. = 2900)

Problem	Possible Cause	Correction
No Power or Inadequate Power	Worn or Malfunctioning pump or motor	Repair or replace pump or motor
	Stuck relief valve cartridge.	Repair or replace
	Low system pressure caused by worn pump.	Repair or replace pump
Surging of hydraulic items	Air in system due to low level of oil, cavitating pump, leaky fittings, pinched hose, etc.	Correct

Removal and Installation of Equipment

1. Preparation

WARNING: BEFORE PERFORMING INSTALLATION OR REMOVAL PROCEDURES THE FOLLOWING PRECAUTIONS MUST BE ADHERED TO IN ORDER TO PREVENT POSSIBLE DAMAGE TO EQUIPMENT OR INJURY OR DEATH TO PERSONNEL.

WARNING: TURN THE ENGINE OFF BY TURNING THE IGNITION SWITCH TO OFF. DISCONNECT THE BATTERY CABLES BEFORE SERVICING THE ENGINE START OR STOP CIRCUITS. DISCONNECTING BATTERY NEGATIVE GROUND BEFORE REMOVING OR CONNECTING THE POSITIVE BATTERY CABLE CAN PREVENT SHORT CIRCUITING OF THE BATTERY BY TOOLS.

2. Electrical (General)

A. Meters, Indicators and Switches Removal.

1. These devices are mounted from the front of the control panel and are secured in place by various types of retainers.
2. Disconnect battery supplying primary power to the device.
3. Disconnect and label all wires on the back of the device.
4. Remove the backside retainer from the device.
5. Remove the device.

B. Meters, Indicators and Switches Installation

1. Insert the device into the control panel space provided.
2. Check that the circuit providing primary power to the device is de-energized.
3. Install the retainer on the backside of the device.
4. Re-connect wiring to device in the same order as it was removed.

Recommended Preventive Maintenance Intervals

INTERVAL	ITEM	PROCEDURE
Initial Break-In	- AFTER FIRST 50 HOURS - Change all hydraulic filters Check for hydraulic leaks Change engine oil and filter Check for loose nuts and bolts Check for excessive wear on all working parts	Tighten as necessary
Daily or 10 hours	Check hydraulic fluid level Check oil level Engine air cleaner system Grease front idler sprocket Check for loose bolts Remove asphalt from all working surfaces	Add as necessary Add as necessary Check service indicator and inspect Grease Tighten as necessary Spray down with approved release agent and clean-off
50 hours	All 10 hour items All bearings Tires (tire units only) Track system (tension, etc.) All linkages	As above Grease Visual Inspection Adjust if necessary Grease
250 hours	All 50 hour items Engine air cleaner Engine crankcase Engine oil filter Fuel tank Hydraulic return filter	As above Replace element Drain and refill Replace Drain water and sediment Replace*
500 hours	All 250 hour items Fuel filters	As above Replace
1000 hours or yearly	All 500 hour items Hydraulic system Engine Radiator	As above Drain and refill, Clean and Grease Valve Solenoid Stem Adjust valves Clean fins with degreaser

* Change after first 50 hours service, every 250 thereafter, and replace with BP Energol HVI 46 or equal hydraulic fluid.

MAULDIN®

CALDER BROTHERS CORPORATION (LIMITED) PRODUCT WARRANTY

Calder Brothers Corporation warrants that the Paver under this program will be free from defects in material and workmanship for a period of (12) twelve months from date of installation. Written notice of any claimed defect must be given to Calder Brothers Corporation within the warranty period and within (30) thirty days after such defect is discovered. Liability under this warranty is limited to replacing or repairing, at Calder Brothers Corporation's election, any part or parts deemed defective after examination by Calder Brothers Corporation or an Authorized Service Representative. Any paver or any of its parts returned by customer to Calder Brothers Corporation or an Authorized Service Representative via prepaid transportation and which is found to be defective will be repaired or replaced and returned to the customer via prepaid surface transportation within the continental United States. Should any part be found not defective, Calder Brothers Corporation or an Authorized Service Representative may charge inspection and handling to the customer.

EXCLUSIONS:

This warranty does not apply to routine wearable parts of the Mauldin paver such as seals, points, plugs, hoses or similar items. This warranty does not extend to any paver or part replaced or repaired under this warranty. This warranty does not cover any repair or replacement labor of any part or parts found defective after examination by Calder Brothers Corporation or an Authorized Service Representative. This warranty does not apply to defects caused by casualty or unreasonable use, including faulty repairs by others and failure to provide reasonable and necessary maintenance.

THIS WARRANTY SET FORTH HEREIN IS IN LIEU OF AND EXCLUDES ANY AND ALL OTHER WARRANTIES, EXPRESSED OR IMPLIED, ARISING BY OPERATION OF LAW OR OTHERWISE, INCLUDING, BUT NOT LIMITED TO, ANY IMPLIED WARRANTY OF MERCHANTABILITY OR FITNESS FOR A PARTICULAR PURPOSE, AND CUSTOMER WAIVES ANY OBLIGATION OF LIABILITY OF CALDER BROTHERS CORPORATION ARISING IN TORT OR STRICT LIABILITY IN TORT, OR FOR LOSS OR USE, REVENUE OR PROFIT WITH RESPECT TO MAULDIN PAVER AND/OR PARTS FOR ANY LIABILITY OF CUSTOMER TO ANY THIRD PARTY, OR FOR OTHER DIRECT, INCIDENTAL OR CONSEQUENTIAL DAMAGES.



PAVER OPERATION MANUAL

MODEL 690-F